

Service-Information



Group 36 Wheels and Tires	February 1984	Bulletin No.: 36 020 84 (2094)
------------------------------	------------------	-----------------------------------

- For U.S.A. and Canada Only -

RE: TIRE CLEARANCE
ALL MODELS EXCEPT R80GS AND R80ST

Dear Dealer:

Occasionally, we receive inquiries of insufficient clearance between the rear swing arm and tire, particularly on motorcycles before model year 1981.

Therefore, a thrust sleeve 10.7mm long has been developed to install on the rear wheel drive side of the wheel hub. This sleeve can be installed in place of the standard 9.2mm long sleeve if more clearance is needed. The sleeve can be ordered through normal parts channels under part number 36 31 2 301 737.

WARNING: If the wider sleeve is installed, the motorcycle's wheel track must always be checked with the wheel alignment gauge and adjusted if necessary to a maximum of 4mm offset.

The line drawing below shows the position of the longer 10.7mm thrust sleeve.

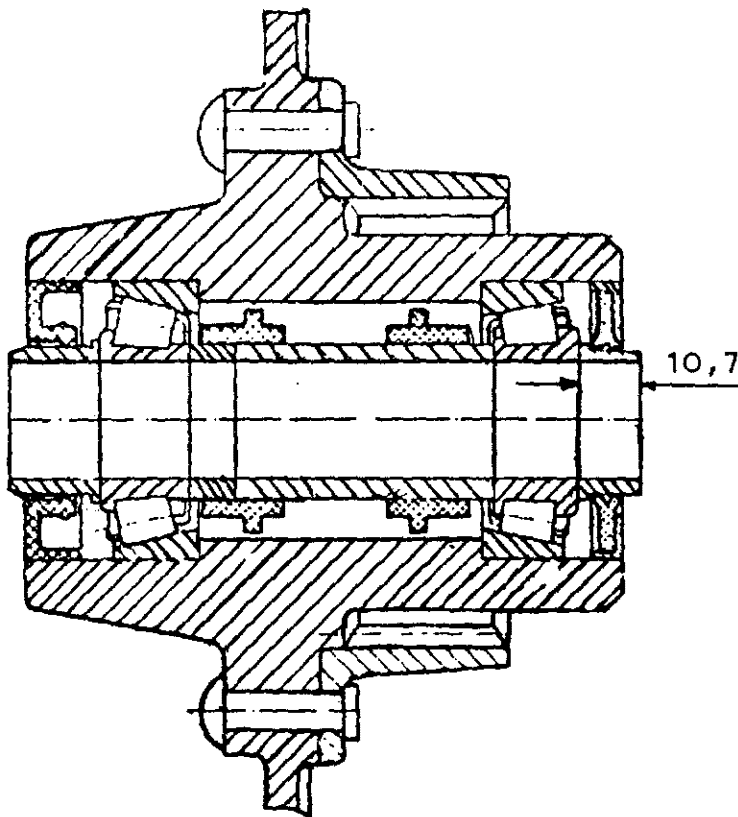

Thrust sleeve
36 31 2 301 737

Sincerely,

BMW OF NORTH AMERICA, INC.

Richard Dampf
National Technical Manager
Motorcycle Group

36 020 84 (2094)