

Service-Information Motorcycle



BMW NA
Service Department

Group: 31
Front
Fork

May 94
31 028 94
(2606)

Fig. 13X Only

Special Tool - Steering Head Bearing Adjustment

Attention: This Service Information supersedes the information in the repair manual PN 01 51 9 798 851 for K 1 and K 100 RS 4 V, on page 2.18.

This Service Information supersedes the information in the repair manual PN 01 57 9 798 777 for K 75, on page 00-43.0.

Tool Part Number: 90 88 6 314 890

Note: This applies to:

K 75	from start of production
K 1	from start of production
K 100 RS 4V	from start of production
K 1100 RS, & LT	from start of production
R 100 R	from start of production
R 100 GS, & PD	from model year 1991

Information: Adjustment of steering head bearings is an essential maintenance procedure to be carried out during the 600 mile service, during the BMW Service, and again during the BMW Inspection.

The use of this special tool gives the technician the ability to lock the locking tube and the adjusting ring together to make more controlled adjustments - and in addition there is now a torque value to set the bearing load. Please review page two for line drawings and adjustment procedures. This procedure can also be reviewed on the K 1100 fiche (01 51 9 799 081), page 14, and on the R 100 GS, R fiche (01 51 9 798 841) page 2.34.

This tool will be sent to all BMW dealers per the Automatic Tool Shipment Program. The cost of the tool will be charged to your parts account.

BMW of North America, Inc.

Joe Wagner
National Service Manager
Motorcycle Group

Daniel E. Browning
National Technical/Training Manager
Motorcycle Group

SI2806 doc

Please initial and route to the following before filing				
Service	Parts	Sales	Warranty	Technicians

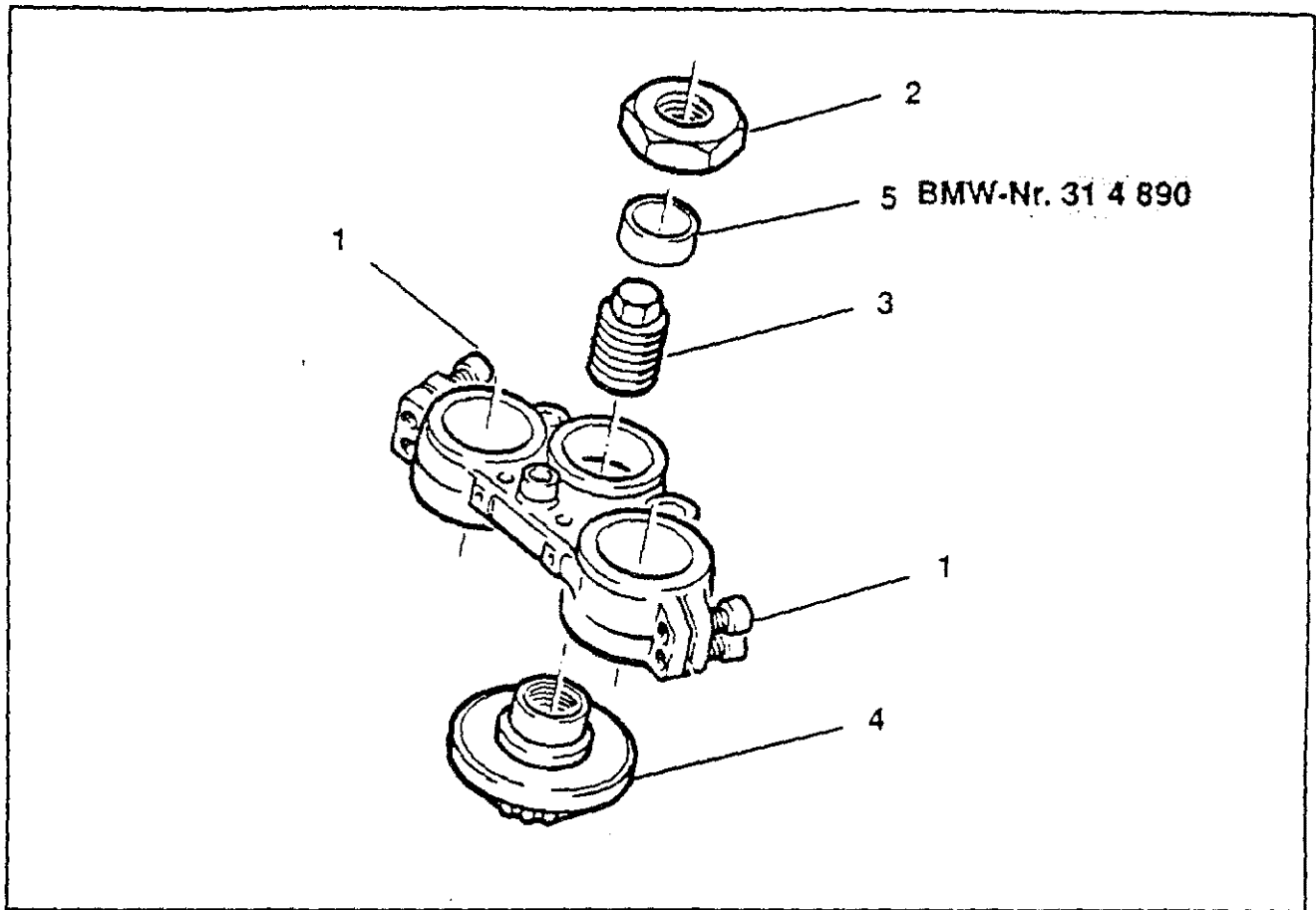

Adjusting steering-head bearing play

- Remove handlebar trim.
- Release handlebar clamping blocks.
- Disconnect cable connectors on bottom at left and right, lift handlebar over ignition lock.
- Slacken off clamp screws at left and right on upper fork bridge (1).
- Release lock nut (2).
- Slacken off lock tube (3) and unscrew through 2-3 turns.

- Push the thrust collar (5) over the lock tube.
- Secure thrust collar with hexagonal nut, holding the lock tube in place when tightening.
- Turn back the adjusting ring slightly via the hexagonal nut, then tighten to the specified torque.

Tightening torque:

Hexagonal nut 12 Nm 9 FT

New bearing:

Pre-tighten hexagonal nut to 25 Nm 18 FT

and move from limit to limit with the steering, slacken off hexagonal nut and retighten to 12 Nm 9 FT

- Mark new position of adjusting ring on the adhesive tape.
- Release hexagonal nut and take out thrust collar.
- Tighten lock tube, tighten hexagonal nut.

Note:

The position of the adjusting ring may no longer be altered!

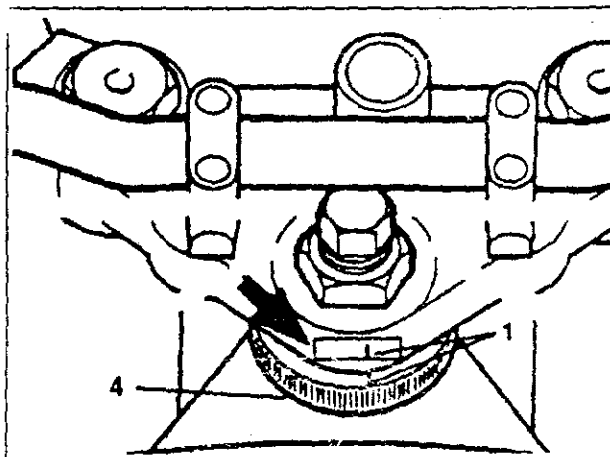

- Affix a strip of adhesive tape (arrow) over the adjusting ring on the fork bridge.
- Mark the current position of the adjusting ring (4) on the adhesive tape and adjusting ring (1).

Tightening torque:

Lock tube 65 Nm 47 FT

Hexagonal nut 65 Nm 47 FT

Clamping screws on fork bridge 15 Nm 12 FT

Clamping block for handlebar 22 Nm 15 FT

- Install handlebar.