

# Service-Information Motorcycle



BMW of N.A.  
Service Department

Group: 11  
Engine

May 1986  
11 032 86  
(2208)

For USA Only

## Installation of 1985 Model R80 Rocker Arm Assemblies on Older Boxers

### Change:

Starting with the 1985 model, all Boxer engines have modified rocker arms as a means of reducing noise and ensuring accurate adjustment of rocker arm endplay.

This modification can be done on all Boxer engines from model year 1976 to the present.

### Features:

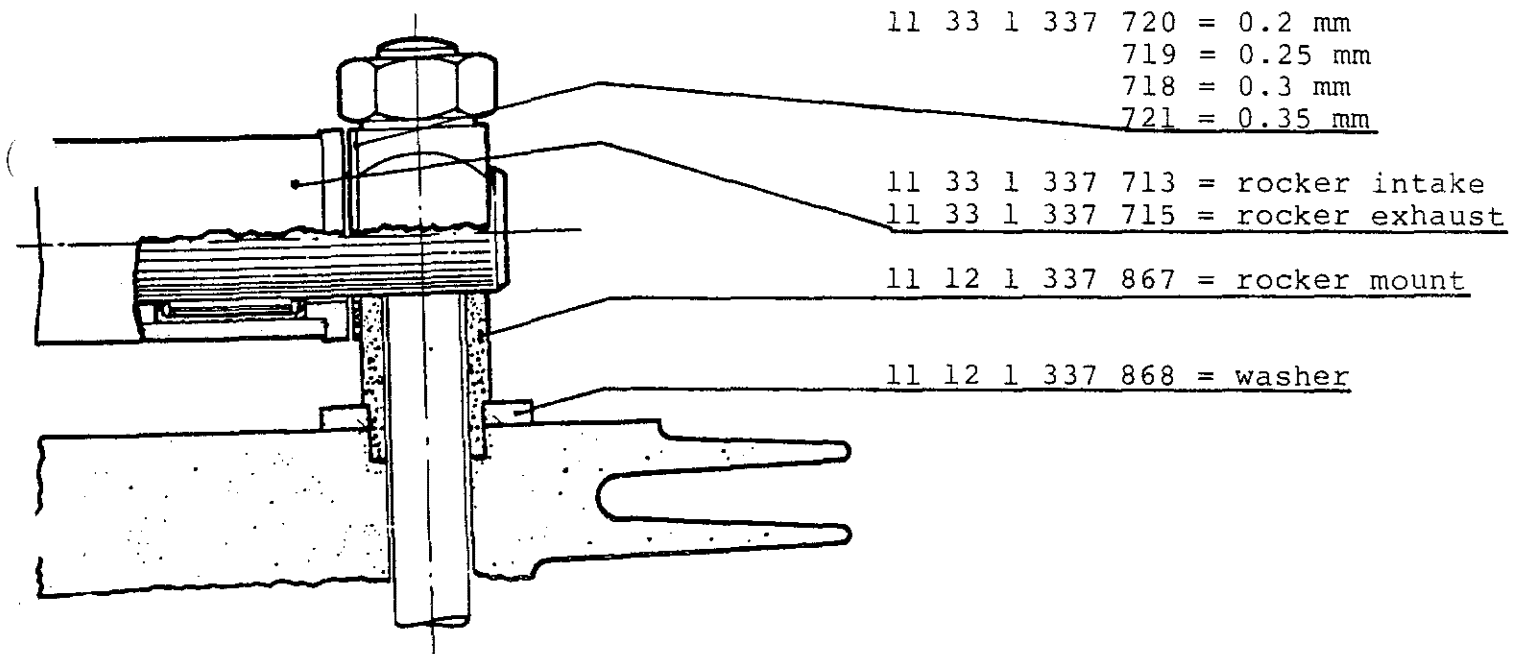

The new rocker arm pivots reduce mechanical noise.

Rocker arm endplay is adjusted to  $0.05 \pm 0.02$  mm by shim washers.

In addition, a pressed-in plastic insert has a damping effect on the noise caused by the rocker arm striking the pivot mount.

As shown in the drawing, silicon rubber inserts prevent the cooling fins from vibrating and causing noise.

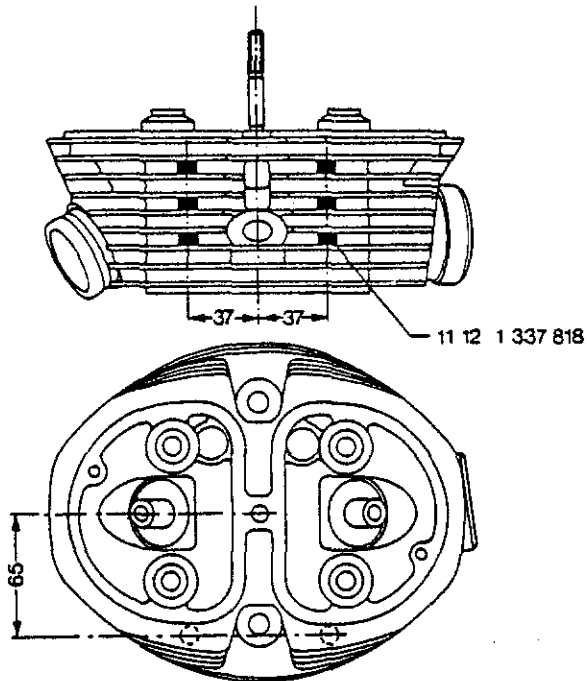

You can order the necessary parts through normal parts channels.

A complete conversion kit can be ordered from our Parts Department under Part No. 11 33 9 057 699.

Note:

Pre-1985 model heads will need support bushings, Part No. 11 12 1 261 405, if the new rocker arm assemblies are used.

Very truly yours,

BMW OF NORTH AMERICA, INC.

Richard Dampf  
National Technical Manager  
Motorcycle Group

RD:ch/033