

Service-Information



Group 46 Frame	May 1983	Bulletin No.: 46 006 83 (2076)
-------------------	-------------	-----------------------------------

- For U.S.A. and Canada Only -

SUBJECT: MODIFIED SIDE STAND R65, R65LS, R100 - R100RT

Dear Dealer:

Starting in January of this year, all the above models have been equipped with modified side stands.

These differ from the previous version as follows: the ball joint is deleted and a modified stop on the frame permits the motorcycle to lean over at a greater angle. The position and design of the extending lever have been improved to make the side stand easier to operate. When the weight is taken off the side stand, it folds up automatically (modified spring action). In addition, the mounting welded on to the frame has been changed to suit the modified mechanism, and provided with a grease nipple. Please use a brand-name multipurpose grease at this nipple during all BMW service and inspections.

The new side stand can be installed subsequently on all motorcycles of model year 1981 or later (except for the R80G/S and ST).

For further details of conversion kits, please refer to the accompanying installation instructions.

Yours truly,

BMW OF NORTH AMERICA, INC.

A handwritten signature in black ink, appearing to read 'Herb Neas', written over a circular stamp.

Herb Neas
National Service Manager

HN/cs

Assembly:

Take off the complete exhaust system.

Detach the return springs from the existing side stand.

Unscrew and remove the pivot pin. Take off the side stand and ball socket.

Clean the pivot mount.

Press the cap into the side stand so that the contact face is against the main centre stand mount after assembly.

Lubricate the side stand, pivot mount and bushing with brand-name multi-purpose grease, and install them. When doing so, coat the thread of the pivot pin with Loctite 242 or 272, and tighten to 16 - 20 Nm (12 - 15 lb/ft).

Attach the spring holder and springs.

Install the exhaust system.

Check that the stand operates correctly.

For the above work, the customer should be charged 7 flat rate units, quoting job number 46 53 000.

Assembly instructions for side stand conversion kit

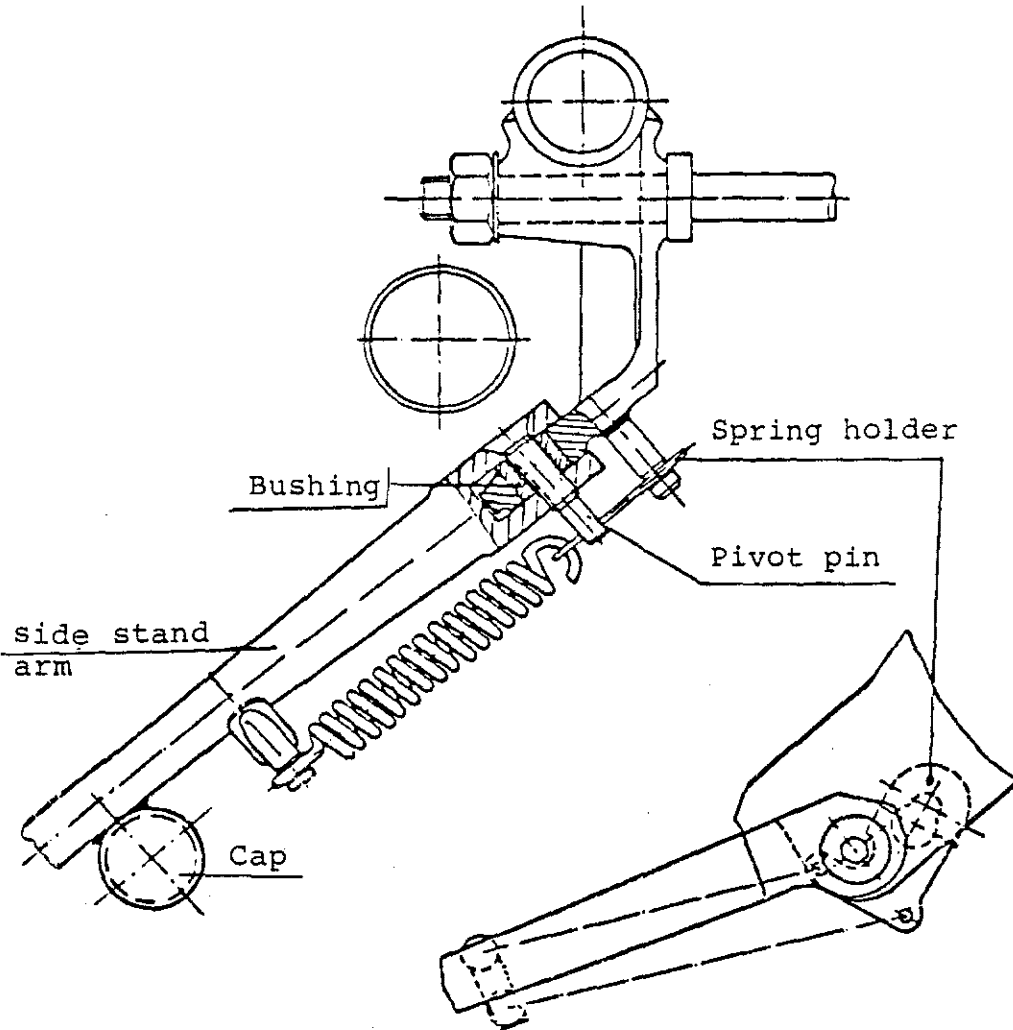

The assembly kits are made up of the following parts:

	Assembly Kit R100 - R100RT	Assembly kit R65 - R65LS
	46 53 2 302 026	46 53 2 302 01
1 side stand	46 53 2 302 003	46 53 2 302 00
1 bushing		46 53 2 302 000
1 cap		46 52 1 236 522
1 pivot pin		46 52 2 302 004
1 spring holder		46 53 2 302 005