

Service-Information



Group: 11 Engine	March 1982	Bulletin No.: 11 021 82 (2050)
---------------------	---------------	-----------------------------------

- For U.S.A. and Canada only -

C A U T I O N

RE: OIL FILTER IDENTIFICATION AND MODEL APPLICATION

Dear Dealer:

Listed below are oil filters with applications as noted:

Item	P/N	Type	Model Application
1.	11 42 1 253 817	Non Cooler, Rigid Type Short	/5,/6,/7 to Current
2.	11 42 1 335 385	Cooler, Rigid Type Long	'79 to Current RT & & RS with Cooler
3.	11 42 1 337 198 *	Non-Cooler, Rigid Type 2 square O-rings	Supplement for P/N 11 42 1 253 817
4.	11 42 1 337 575 *	Cooler, Flexible Type, 2 square O-rings	Supplement for P/N 11 42 1 335 385
5.	11 42 1 337 570 *	Non-Cooler, Flexible Type, 2 square O-rings	Supplement for P/N 11 42 1 337 198

* 1982 Production Models

CAUTION: PLEASE NOTE LOCATION, TYPE AND NUMBER OF O-RINGS USED PER APPLICATION.

ANY FAILURES DUE TO MISSING OR IMPROPER USE OF O-RINGS WILL NOT BE HONORED UNDER THE VEHICLE OR PARTS WARRANTY.

INSTRUCT YOUR PARTS PERSONNEL TO WARN AND INSTRUCT YOUR CUSTOMERS THAT DO THEIR OWN OIL CHANGES.

ITEM 1. P/N 11 42 1 253 817, Non-Cooler, Rigid Type,
Models: /5 /6 /7 to Current:

(/7 style Cap and Cannister shown)

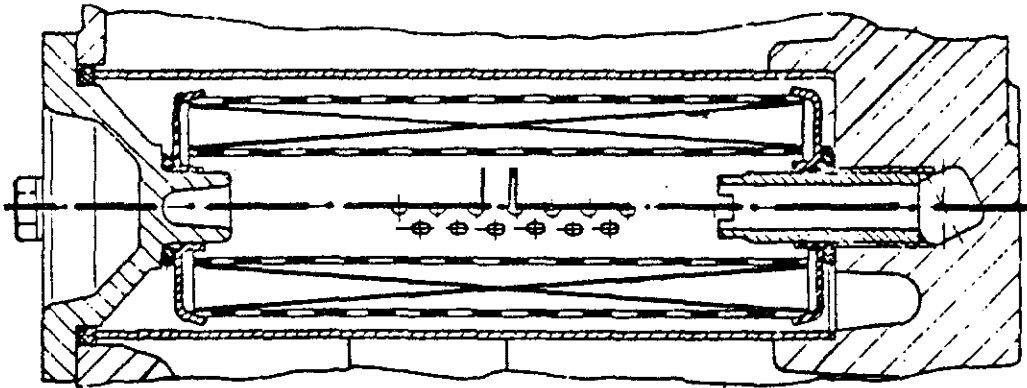

NOTE: Filter w/2 13 x 3.5 mm O-rings

ITEM 2. P/N 11 42 1 335 385 Cooler Rigid Type, '79 to Current
RS + RT w/Cooler

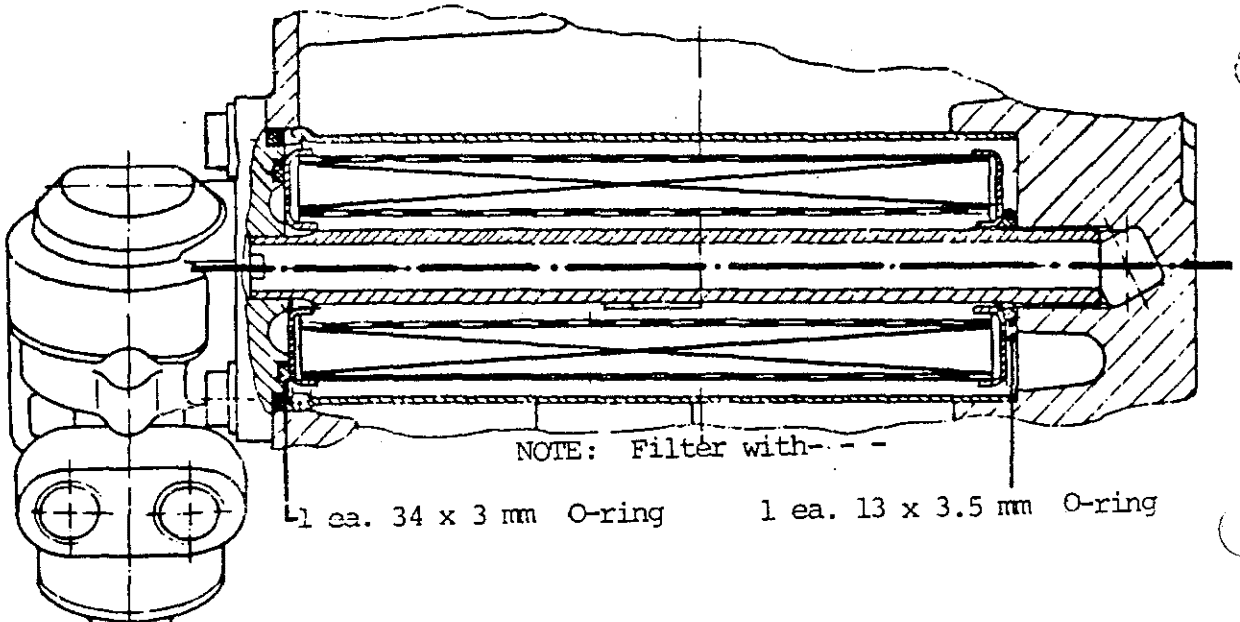

NOTE: Filter with---

1 ea. 34 x 3 mm O-ring

1 ea. 13 x 3.5 mm O-ring

ITEM 3. P/N 11 42 1 337 198, Non-Cooler Rigid Type, w/2 square o-rings. Supplement for P/N 11 42 1 253 817.

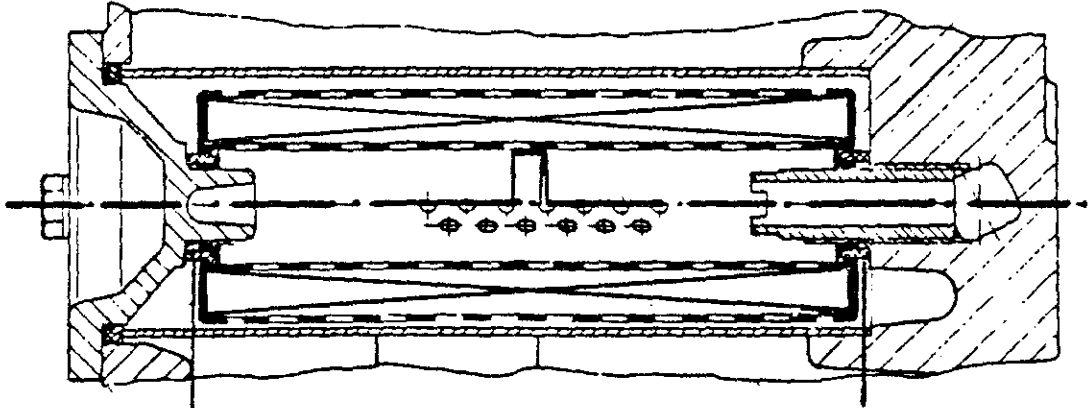

NOTE: Filter w/2 square o-rings. The 13 x 3.5 mm o-rings are deleted.

ITEM 4. P/N 11 42 1 337 575, Cooler Flexible Type, w/1 square O-ring. Supplement for P/N 11 42 1 335 385.

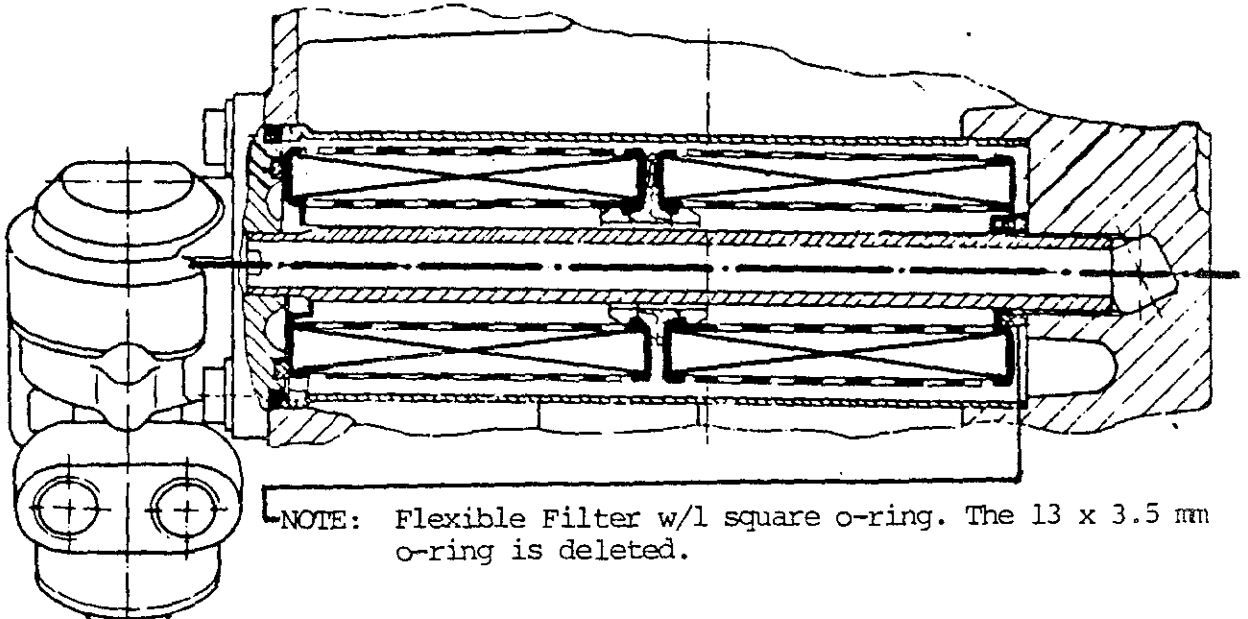

NOTE: Flexible Filter w/1 square o-ring. The 13 x 3.5 mm o-ring is deleted.

ITEM 5. P/N 11 42 1 337 570, Non-Cooler, Flexible Type, w/2 square o-rings.
Supplement for P/N 11 42 1 337 198.

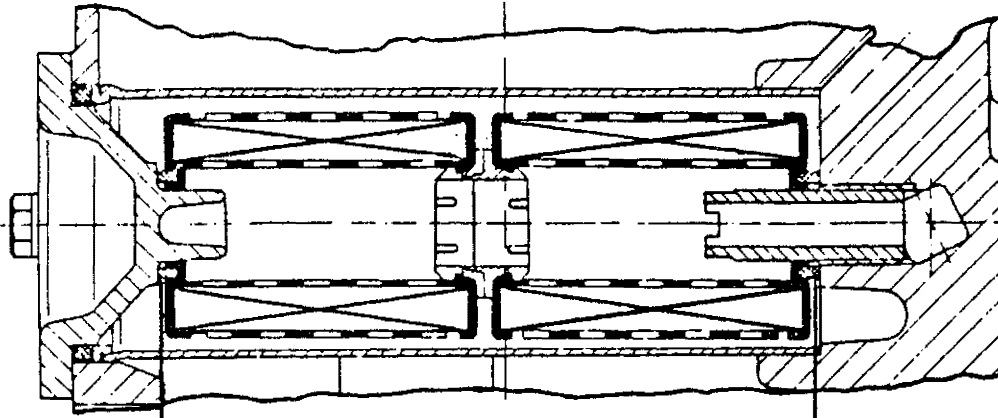

NOTE: Flexible Filter w/2 square O-rings. Both 13 x 3.5 mm
O-rings are deleted.

NEW OIL CANISTER

Also during the 1982 model production, the oil canister has changed.

Previous model used 1 o-ring, 1 shim and 1 paper gasket to seal the
filter cover. (See Illustration 1.)

Illustration 1.

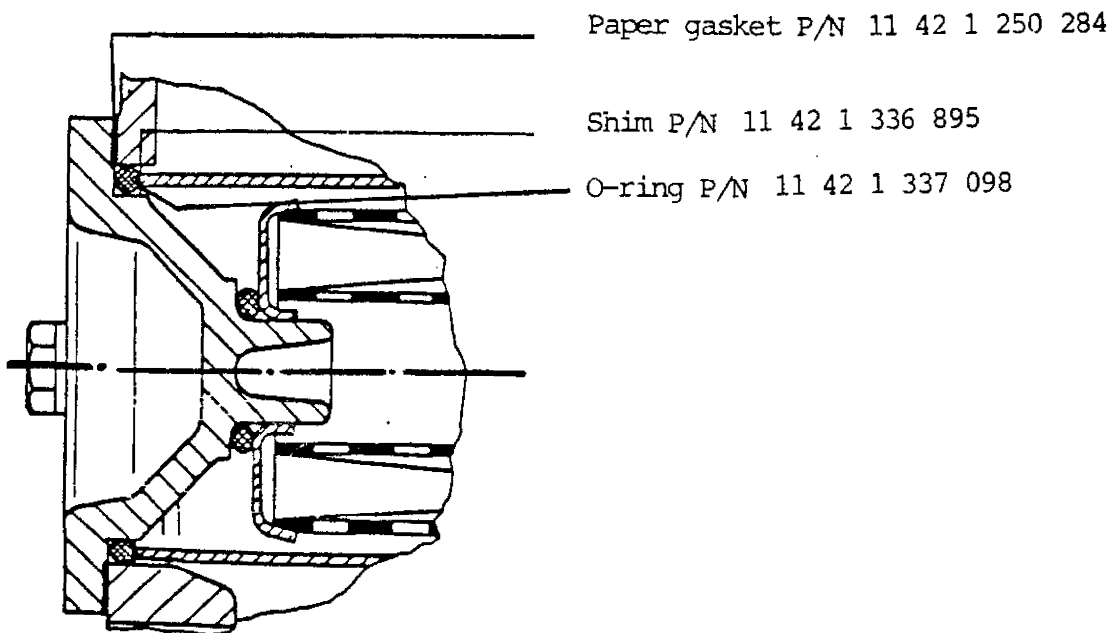
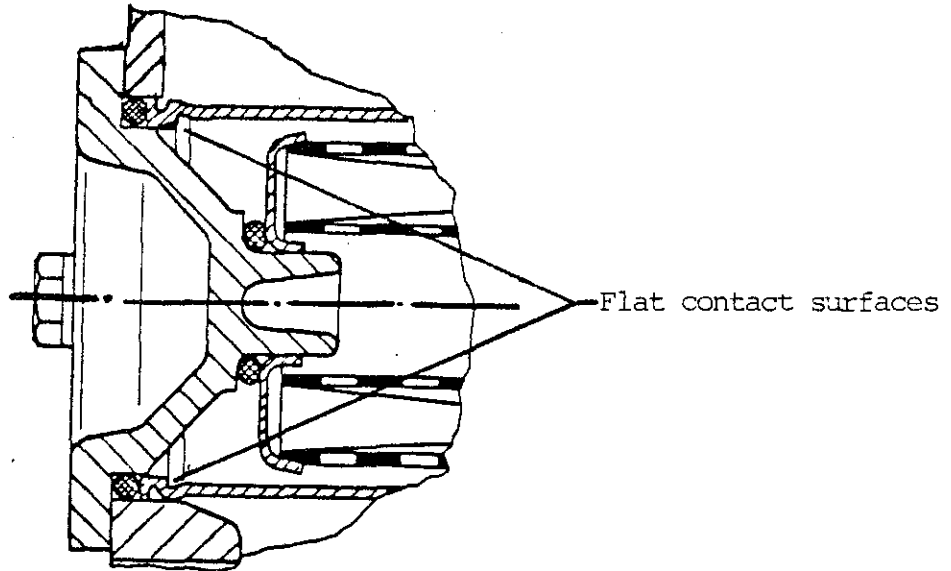

Illustration 2.



NOTE: On repair jobs, new 1982 oil filter canister can be used in place of previous types.

Yours truly,

BMW OF NORTH AMERICA, INC.

H. Neas
National Service Manager

HN/vaa