

# Service-Information



Group: 33 Rear Wheel Drive	June 1982	Bulletin No. 33 007 82 (2062)
-------------------------------	--------------	----------------------------------

- For U.S.A. and Canada only -

RE: NIVOMAT IMPROVEMENT KIT

Dear Dealer:

After extensive testing, we are pleased to make available a helper spring kit for all Nivomats (with exception of the latest 1982 Nivomat identified by a black bottom leg stamped "L").

This kit is available under

Part No. 33 53 2 301 787.

from our Parts Department.

We all know it needs a fairly good size bump to "pump up" a standard Nivomat riding levels. The additional spring will insure quicker riding levels, due to stronger pump actions even over smaller bumps.

Enclosed find dismantling and assembly instructions.

CAUTION: Care must be taken not to damage the piston rod when clamping same into a vise or the entire Nivomat is useless.

Correct jaws, as illustrated on the instruction sheet, must be used.

Yours truly,

BMW OF NORTH AMERICA, INC.

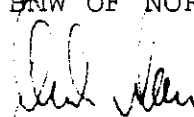
  
Herb Neas  
National Service Manager

HN/vaa  
enclosure

Please route and initial before filing

Service Manager	Parts Manager	Service Writer	Technicians
-----------------	---------------	----------------	-------------

DISMANTLING

Lift the support disc (3) away as shown by the arrow, release snap ring (2) and remove both components downwards together with spring centering plate (5), coil springs (7) and (8) and flexible gaiter (9). To free the sealant at the screw connection between piston rod and retaining eye, heat the joint area to approx. 250° C. Hold the piston rod in the special jaws (faces absolutely clean) and unscrew retaining eye (1) while hot. The eye (1), cup (4), centering plate (5) and rubber buffer (6) can be discarded; they are replaced by the parts stated in "Assembly."

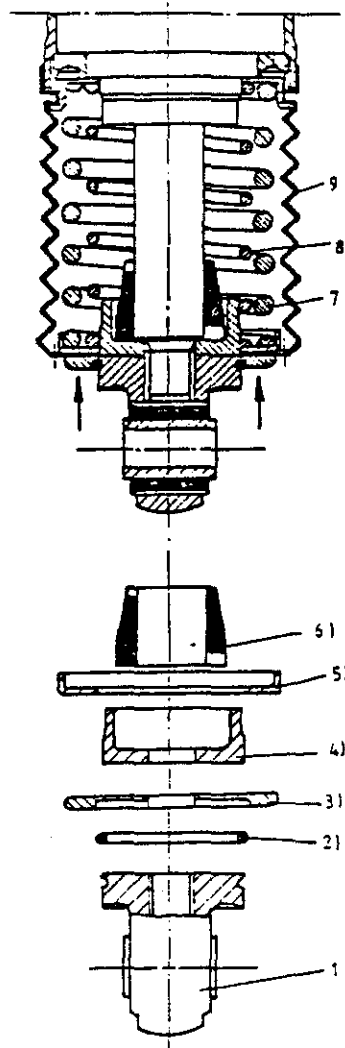

CLAMPING

(for dismantling/assembly)

Jaw position (as low as possible to avoid compressing the hollow drilled shaft.)

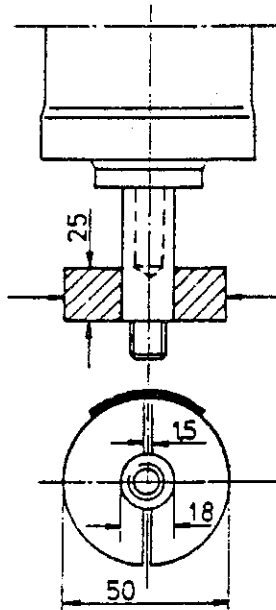

Material: Aluminium