

# Service-Information Motorcycle



BMW of N.A.  
Service Department

Group: 34 March 1985

Brakes 34 008 85  
(2148)

For USA and Canada  
Only

## 1985 R80 & R80RT Double Disc Front Brakes

Two types of front disc brake systems will be delivered on U.S. models of the motorcycles named above.

- 1.) Double discs with two (2) rubber hoses, on to each caliper; and
- 2.) Double discs with one (1) rubber hose to the left brake caliper and a pipe from the left caliper to the right caliper.

Both systems will accept engine protection bars; however, on the version with two rubber hoses, on the R80, it is important to install the hoses into the wire holders which mount onto the upper mounting of the engine protection bars.

Failure to install the hoses in this manner could impair steering (i.e., hoses could hang up on the upper mounting of the engine protection bar).

Very truly yours,

BMW OF NORTH AMERICA, INC.

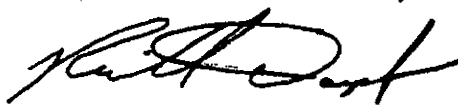
  
Richard Dampf  
National Technical Manager  
Motorcycle Group

RD:ch

two (2) rubber hoses

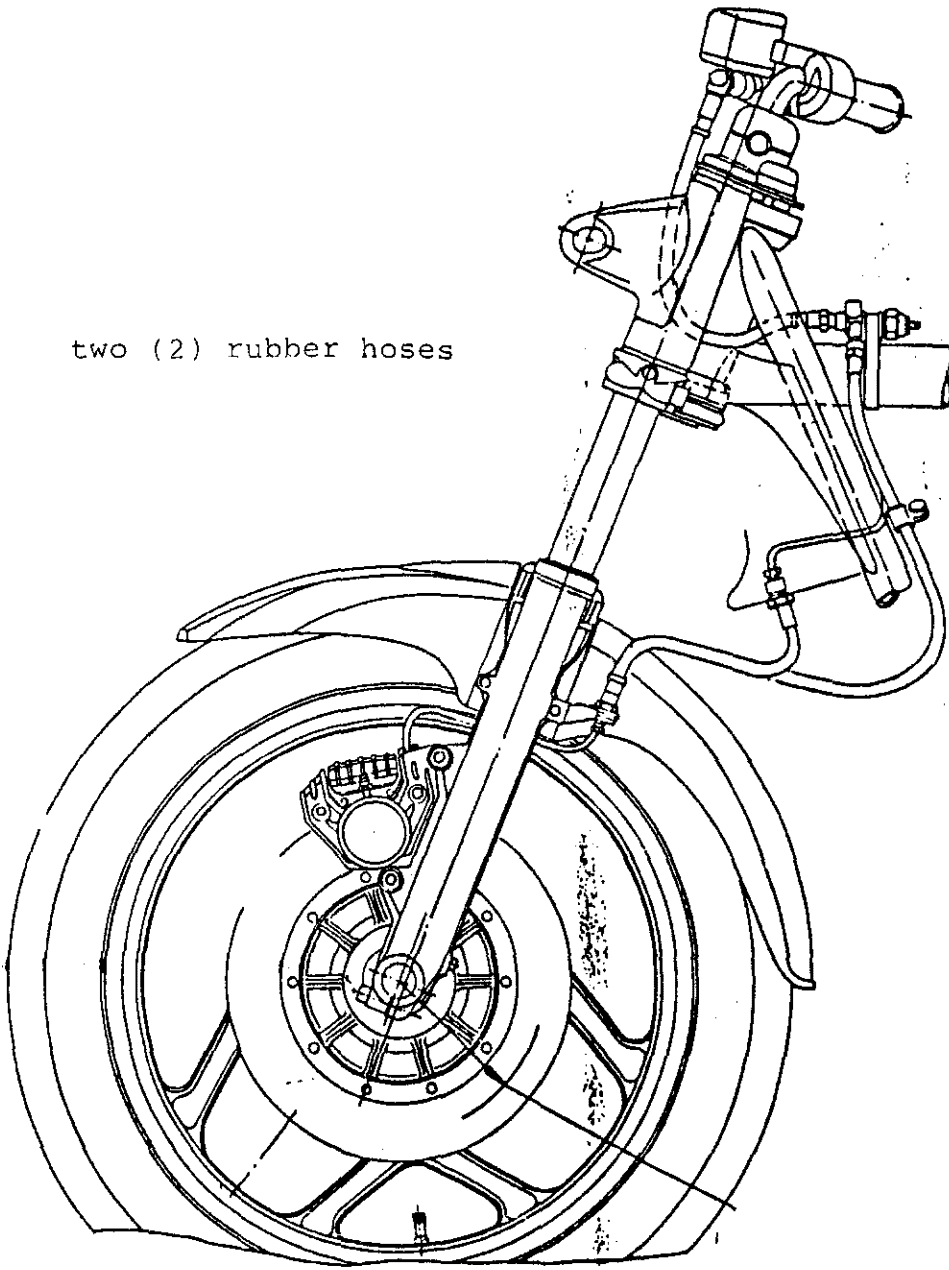

one (1) rubber hose

