

SERVICE INFORMATION

Customer Service
V.GmbH/B&S, N.J.

Motorcycle R 75/5
Group Engine

New Jersey, Apr. 1970
No. 4/70 (285)

Re: Constant Velocity Carburetor

Gentlemen:

Constant velocity carburetors are more critical and therefore, require that the tuning procedures are precisely followed otherwise irregular idle, poor performance, surging in mid-range and slow return to idle may occur. Tune as follows:

1. Remove and dismantle carburetor.
2. Make certain that the slide pilot sleeve has sufficient clearance in the dome bushing to allow the slide to fall freely of its own weight. The desired clearance is 0.07 mm (.003"). It is very important to have this clearance. To obtain this, ream the bushing in the cover with an adjustable reamer. Polish the guide bushing and pilot sleeve with crocus cloth. Install the slide dry.
3. In case surging was experienced, raise the slide needle to the third notch from the top by twisting 90° and pushing it in. Exposed portion of needle below slide in third notch from top is 39.5 mm (1.555"), second notch used to be 41.2 mm (1.622").
4. Before assembling the carburetors, clean all components.
 - A. Inspect diaphragm for cracks, tighten dome screws slowly alternating in an X pattern and make certain the slide moves very freely when the 4 screws are fully tight.
 - B. Check choke operation, lever has to move freely and close through the internal spring.
 - C. Adjust carburetors to their basic setting.
 1. Back off butterfly adjusting screw until it is clear of the operating lever. Tighten screw until it just touches the lever and then tighten one full turn.

Kenntnis genommen — Pris connaissance — Noted — Tomado nota — Preso conoscenza					Ablage — Archives — File — Archivo	
Betriebsleitung Direction Management	Werkstatt Atelier Workshop	KD-Annahme Réception clientèle Cust. reception Recepción clientela	Gewährl.-Sachb. Inspecteur garantie Warranty inspector Inspector garantía	E-Teildienst Service pièces détachées Spare parts service Servicio de repuestos	Betriebsleitung Direction Management	Werkstatt Atelier Workshop

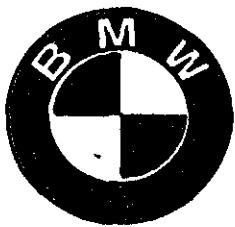

SERVICE INFORMATION

Customer Service
V.GmbH/B&S, N.J.

Motorcycle R 75/5
Group Engine

New Jersey, Apr. 1970
No. 4/70 (282)

- 2 -

2. Carefully tighten mixture screw and then back off one full turn.
- D. Move butterfly lever from stop to stop to make sure that it doesn't bind and that nothing interferes with its full movement.
5. When installing the carburetor, slot the air intake tubes as shown in the enclosed drawing. Deburr the inside of the intake tubes on both ends. Coat the inside of both ends of the tubes with Hylomar. This will prevent any dirt and moisture from entering the intake (available from B & S).
6. Adjust both choke cables to have 0.5 to 1 mm (.020-.040") free play. Release the adjustment on the throttle cables, so they do not interfere during the idle adjustment.
7. Check proper float level with the motorcycle on the center stand and level.
 - A. Pull back wire clip from float bowl.
 - B. Hold float bowl to bottom of carburetor and open petcock.
 - C. Allow float bowl to fill up. When you are sure that fuel has stopped flowing, close petcock and quickly remove float bowl from carburetor.
 - D. Place float bowl on level surface and measure the amount of fuel in the bowl. Measure in the middle of bowl from the lowest point up to the level of the fuel. There should be 19.5-20 mm (.767-.787") of fuel in the bowl.
8. Start motorcycle and let it warm up.
9. Disconnect right hand spark plug wire. (Install an adaptor into the cap to prevent the cap from being damaged). Adjust butterfly stop screw on left cylinder to obtain the slowest possible idle. Correct mixture

Kenntnis genommen — Pris connaissance — Noted — Tomado nota — Preso conoscenza				Ablage — Archives — file — Archivo		
Betriebsleitung Direction Management Dirección	Werkstatt Atelier Workshop Taller	KD-Annahme Réception clientèle Cust. reception Recepción clientela	Gewährl.-Sachb. Inspecteur garantie Warranty inspector Inspector garantía	E-Teildienst Service pièces détachées Spare parts service Servicio de recambios	Betriebsleitung Direction Management Dirección	Werkstatt Atelier Workshop Taller

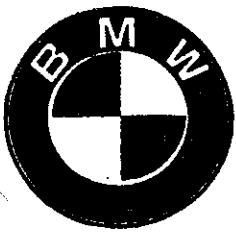

SERVICE INFORMATION

Customer Service
V.GmbH/B&S, N.J.

Motorcycle R 75/5
Group Engine

New Jersey, Apr. 1970
No. 4/70 (282)

- 3 -

adjustment to obtain maximum RPM. Readjust butterfly stop screw again for slowest possible idle. Again adjust mixture screw to obtain highest possible RPM. This procedure has to be repeated until the cylinder operates only on the idle fuel system.

10. Repeat the same procedure on the right hand cylinder.
11. Connect both spark plug caps and let engine idle on both cylinders. Reduce the idle speed alternately left and right until the engine idles at 600-800 RPM. This is done by slightly backing off the butterfly screw and correcting the mixture to optimum, as is done in Step 9, only with both cylinders operating.
12. Recheck that both cylinders have the same idle speed, that both die after several strokes, by alternately pulling off the spark plug caps. The final engine idle should be between 600 and 800 RPM.
13. Adjust both throttle cables equally to 0.5 to 1 mm (.020-.040") free play and make certain that they pull evenly by alternately pulling spark plug caps left and right at approximately 4,000 RPM.
14. Do not allow engine to idle for perlonged periods.
15. If a change in operation is noted after a test ride, it is possible that the engine was loaded up during the adjustment procedure.

Bayerische Motoren Werke
Aktiengesellschaft

Volker Beer
- Volker Beer -

Kennnis genommen — Pris connaissance — Noted — Tomado nota — Preso conoscenza				Ablage — Archives — File — Archivo		
Betriebsleitung Direction Management Dirección Direzione	Werkstatt Atelier Workshop Taller Officina	KD-Annahme Réception clientèle Cust. reception Recepción clientela Recezione clienti	Gewährl.-Sachb. Inspecteur garantie Warranty inspector Inspector garantía Isnettore garanzie	E-Teildienst Service pièces détachées Spare parts service Servicio de recambios Servizio ricambi	Betriebsleitung Direction Management Dirección Direzione	Werkstatt Atelier Workshop Taller Officina

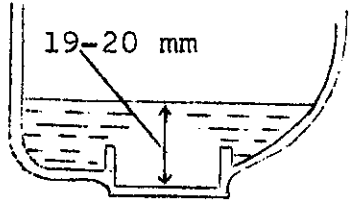
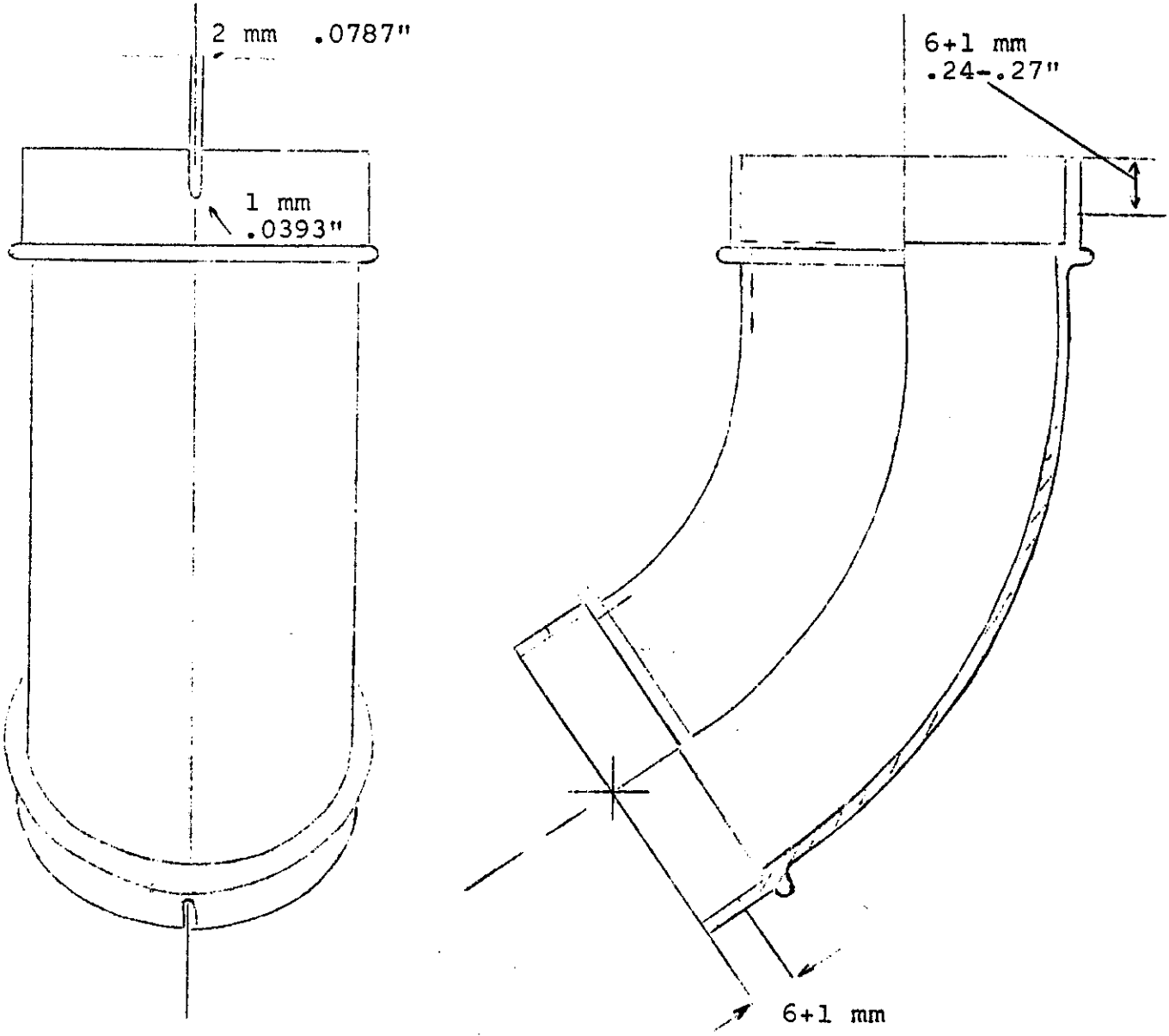

Float Bowl Level

Handwritten signature or initials.