

Service-Information



Group 21 CLUTCH	April 1983	Bulletin No.: 21 003 83 (2074)
--------------------	---------------	-----------------------------------

RE: CLUTCH

Dear Dealer:

Comprehensive modification has been introduced in the clutch area:

1. The clutch plate has been completely redesigned to withstand extreme loads.

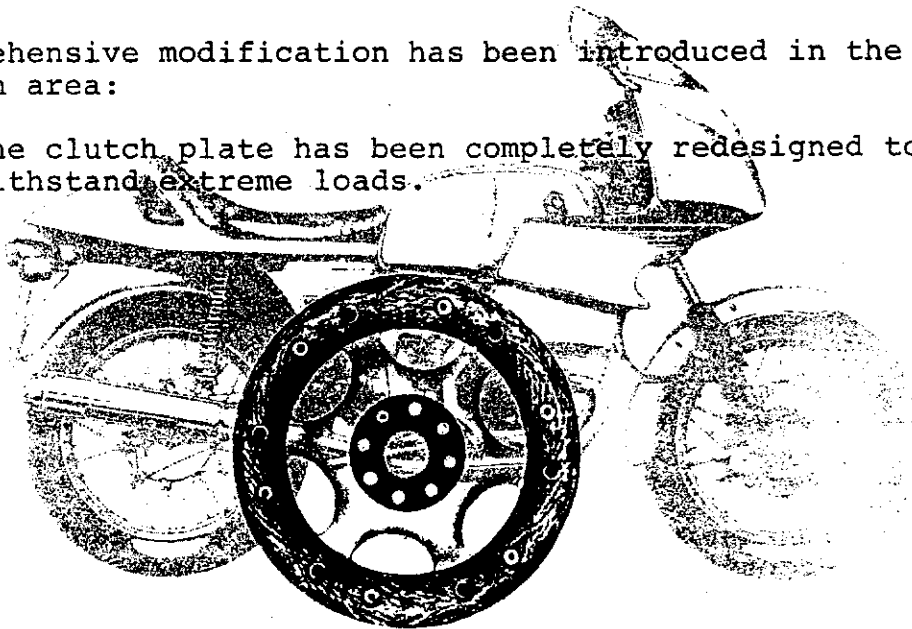

New part No.: 21 21 1 451 512.

This clutch plate is interchangeable on all models since 1981.

Please route and initial before filing

--	--	--	--

2. Clutch carrier

The clutch carrier also has been strengthened.

New clutch carrier part No.: 21 21 1 451 511.

Former clutch carrier part No.: 21 21 1 242 372.

Both clutch carriers are fully interchangeable.

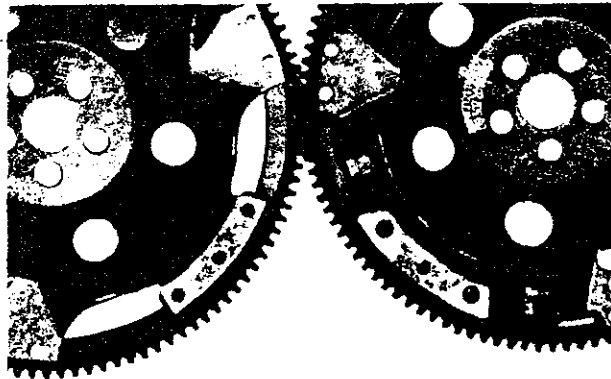

Old

New

Hint: To ensure proper pre-tension of the diaphragm spring according to the spring rate, washers (0.2 - 0.4mm) have been inserted on the production line between clutch carrier and cover, on a limited amount of motorcycles.

These washers had to be used to correct reworking of the cover.

Covers obtained via Parts Department do not need the washers.

Clutch slipping, which is not caused by a greasy or glazed clutch lining, can be rectified by exchanging the cover.

3. Installation hint:

To ensure smooth clutch action, all places marked with * should be lubricated with a high-temperature grease, according to our prior recommendation. Please make sure that no grease can get to the clutch lining.

When installing the clutch, the three white balancing marks should be displaced approximately 120° to each other. This will ensure the clutch is balanced.

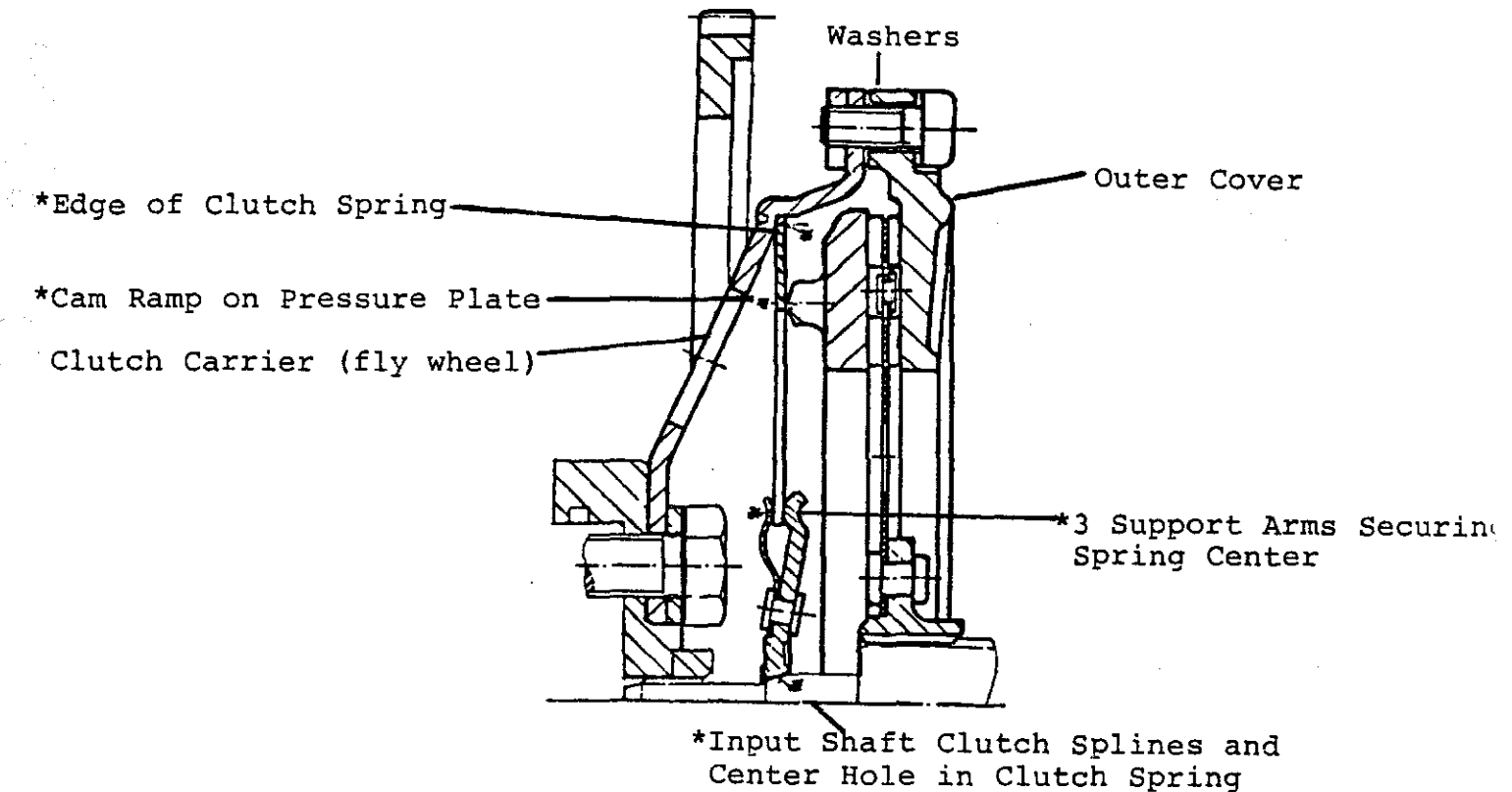

4. Shifting problems

Hint:

The clutch splines and gearbox input shaft splines should be lubricated with a special grease, according to our recommendation.

Caution:

Before lubricating the parts, it is necessary to degrease them carefully so that no old grease or dirt is left. Proper cleaning will insure effectiveness of lubrication.

We recommend the use of Optimol Paste PL on all clutch components exclusively.

Yours truly,

BMW OF NORTH AMERICA, INC.

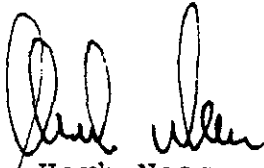

Herb Neas
National Service Manager

HN/cs

Paste PL can be ordered from:

Optimol Lubricants, Inc.
Minue Street
Carteret, NJ 07008
201-969-2200