

# Service-Information Motorcycle



©BMW of N.A.  
Service Department

Group:

34

July, 1992  
34 027 92  
(2537)

For USA Only

Brakes

Brake Pad Recall 92 V-081 Procedures  
1990 - 1993 Models, R100R, K100RS-16v, K1, K1100LT

NOTE: Revised August 1992: Due to warranty data entry we have revised this S.I. to show additional work packages. The time has not changed, only the work package numbers have been changed.

This Recall affects a relatively small number of 1990 - 1993 motorcycles.

Affected VIN Range:

Year	Model	VIN Range	Number of MC's
1992	R100R	0280001 - 0280373	373
1990-1992	K100RS-16v	6493001 - 6494091	1,091
1990-1992	K1	6365002 - 6365646	645
1993	K1100LT	0300001 - 0300375	375
			<u>2,484</u>

**Problem:** The front brake pads could begin to separate from their backing plate, due to corrosion of the plate. This may happen when the motorcycle is operated in coastal areas and on roads where salt has been spread. If the pads are not replaced, eventually they could completely separate from the backing plate.

**Parts:** Determine the number of affected motorcycles that are within your dealership as well as those sold retail and order quantities to satisfy that number.

Order the following P/N: 34 11 9 062 616 = 1 set of 2 pads

Remember that dual disk models require 2 sets.

**Identification:**

The new brake pads can be identified (in addition to the new part number) by a white paint dot near the mounting pin hole.

Please initial and route to the following before filing				
Service	Parts	Sales	Warranty	Technicians

## Installation Instructions:

- Remove the front fender to gain access to the calipers on the K1 and K1100LT models.
- Remove the brake caliper from the front fork (there is no need to detach the brake hose).
- Knock out the safety pin and remove the pads in a downward direction.
- Using special tool 88 88 6 341 500 press the caliper positions back into each caliper half.
- Install new brake pads, P/N 34 11 9 062 616 and reinstall the safety pin.
- Reinstall the caliper on the front fork leg. Tightening torque is 32 nm (23 ft/lb).

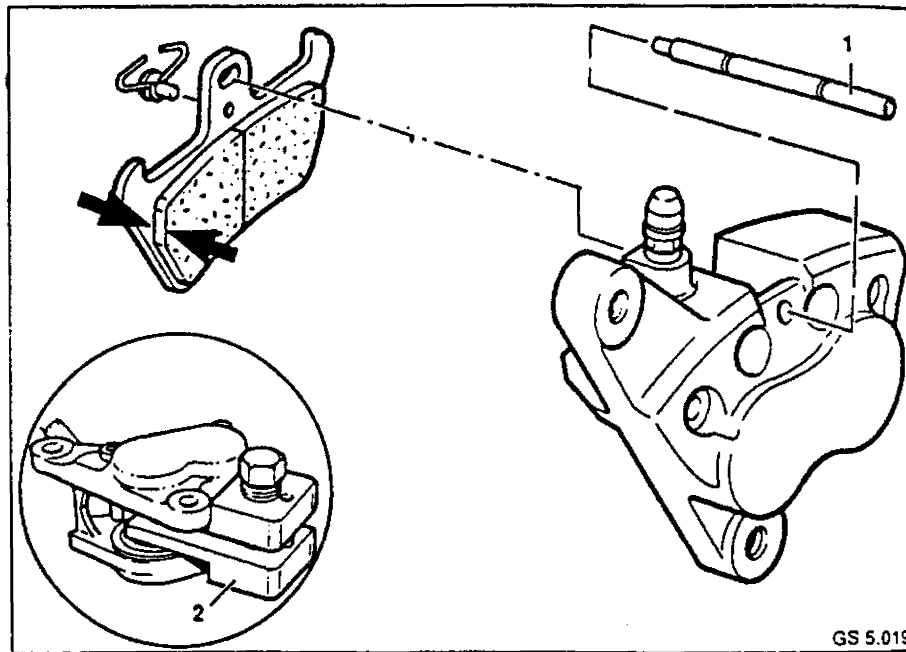

**Warranty**

**Status:** All affected motorcycles, regardless of time in service or mileage, will be reimbursed for this recall through campaign claim submission. Please read Section 4, pages 15 - 17 of the BMW Motorcycle Warranty Policies and Procedures Manual for complete information about these special claims.

**Work Package #1:**

Is used for all models with single disk brake (R100R).

Defect Code: 00 00 34 1200  
Flat Rate No.: 34 11 000  
Flat Rate Units: 3 = (15 min.)

This defect code will reimburse 1 set of brake pads.  
Part No. - 34 11 9 062 616

**Work Package #2:**

Is used for all K100RS -16v models with dual disk brakes.

Defect Code: 00 00 34 1200  
Flat Rate No.: 34 11 008  
Flat Rate Units: 4 = (20 min.)

This defect code will reimburse 2 sets of brake pads.  
Part No. - 34 11 9 062 616

**Work Package #3:**

Is used for all K1 models.

Defect Code: 00 00 34 1200  
Flat Rate No.: 34 11 0008  
Flat Rate Units: 5 = (30 min.)

**Work Package #4:**

Is used for all K1100LT models.

Defect Code: 00 00 34 12  
Flat Rate No.: 34 11 008  
Flat Rate Units: 5 = (25 min.)

Brake pads which are replaced will be requested through warranty parts return.

**Defective Brake Pads  
in Dealer Parts Inventory:**

All brake pads in your parts inventory identified by P/N 34 11 2 310 983 must be removed from stock.

Use a normal warranty claim with the following information for claim reimbursement.

Defect Code: 00 00 34 1300  
Warranty Type: 2  
Chassis No.: 4990100  
Flat Rate No.: 34 99 000  
Flat Rate: 1 = 5 min.

In addition to brake pads in your inventory, you may have complete brake calipers with P/N's:

34 11 2 310 045 - Left  
34 11 2 310 046 - Right

These calipers also need to be modified using new brake pad 34 11 9 062 616.

**Identification:** Please affix a special label (see S.I. #2351 or 2468 - Group 1) to the motorcycle frame (under the seat) with the number 10 punched out to identify that the Recall has been performed on the motorcycle.

If a special label with a different number is already on the motorcycle from a previous action, replace that label with a new one punched for all completed actions (past and present).

Special Action  
Label Number: 10



Very truly yours,

BMW of North America, Inc.

Handwritten signature of Frank Stevens.

Frank Stevens  
National Service Manager  
Motorcycle Group

Handwritten signature of Richard Dampf.

Richard Dampf  
National Technical Manager

FS:tb/42.5