



SERVICE INFORMATION

Techn. Customer Service VKT-20	Motorcycle R 50/5, R 60/5, R 75/5 Group: electricity	Munich, Nov. 70 No. 2/70 (287) eng.
-----------------------------------	---	--

RE: Blinker control

Dear Sirs,

following a customer demand we fitted a blinker control as from

type R 50/5 chassis No. 2 901 379
 type R 60/5 chassis No. 2 932 142
 type R 75/5 chassis No. 2 972 388

The blinker control light is in driving direction left nearby the ignition and light switch in the headlamp and consists from the following parts

<u>name</u>	<u>ordering No.</u>
control lamp green, without lamp H 12 V 2 W	63 12 1 353 487
line for control lamp	61 12 1 353 489
rubber ring for control lamp	63 12 1 353 486

The parts can be ordered in the usual way.

The blinker control can be also re-fitted against facturation. Make the bore 17 + 0,2 mm dia. following chart I, a = 55 mm, should be taken from the imaginary middle line of the headlamp with a circle.

Contact the lines following chart II.
In chart II

pos. 1 means	control lamp
pos. 2 means	blinker sender
pos. 3 means	connection.

Yours very truly,
 BAYERISCHE MOTOREN WERKE
 Aktiengesellschaft.
 ppa. i.V.

Kennnis genommen - Pris connaissance - Noted - Tomado nota - Preso conoscenza Abzug / Archives - File - Archivio

Betriebsleitung Direction Management	Werkstatt Atelier Workshop	KD-Annahme Réception clientèle Cust. reception	Gewährf.-Sachb. Inspektion Warranty Inspector	E-Teildienst Service pièces détachées Spare parts service	Betriebsleitung Management	Werkstatt Atelier Workshop
--	----------------------------------	--	---	---	-------------------------------	----------------------------------

I

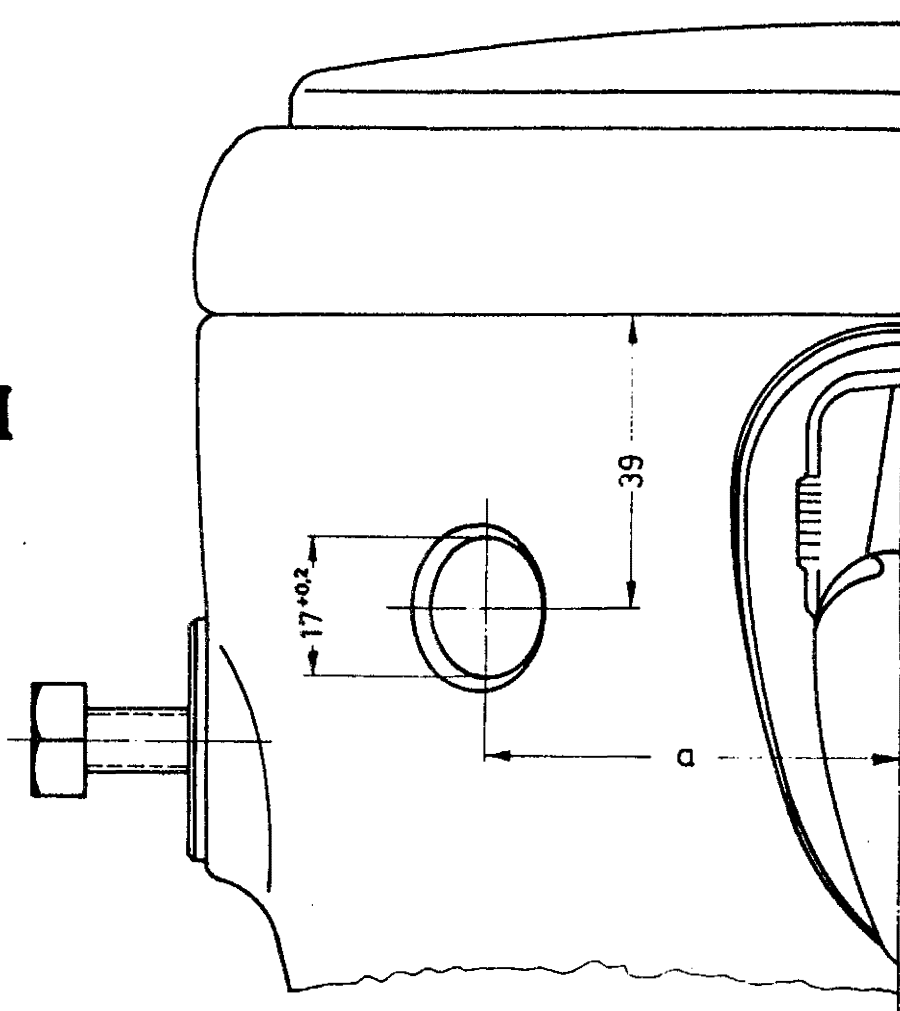

II

